

## **Linking Personality Traits and School Dropout Tendency: Evidence from Pakistan Orphan and Non-Orphan Students**

**Rimsha Majeed<sup>1</sup>**

University of Memphis

**Muhammad Aqeel<sup>2</sup> & Tamkeen Zahra Shah<sup>3</sup>**

Foundation University, Rawalpindi Campus

**Rafia Komal<sup>4</sup>**

National University of Sciences and Technology (NUST)

Existent research bears scarce evidence of the influence of personality traits on the school dropout tendency of students, particularly indicating the need for a focus on how a combination of various personality traits might precipitate dropout. Furthermore, there is a gap in terms of how personality traits interact with the circumstance of being an orphan student to affect drop-out decisions. Addressing this gap, the current research was designed to investigate the influence of various personality traits on the school dropout tendency of orphan and non-orphan students. Two hundred participants (orphan students,  $n = 100$ ; non-orphan students,  $n = 100$ ) were included from different orphanage schools and high schools of Rawalpindi and Islamabad, Pakistan. The age of the participants ranged from 12-18 years. Purposive sampling was conducted based on cross-section design. Two scales, the Eysenck personality questionnaire (EPQ: Eysenck, Eysenck, & Barrett, 1985; Naqvi, 2001) and School Refusal Assessment Scale-revised (SARS-R: Kearney, 2002) were employed to respectively measure extraversion-introversion, neuroticism, and psychoticism traits of personality, and students' dropout tendency. This study found that extraversion-introversion was linked to a greater likelihood of school dropout tendency in orphanage students. Furthermore, the study revealed that low prevalence of neuroticism increased probabilities of an early exit. On the other hand, the investigation also indicated that psychoticism and lie traits of personality were associated with higher probabilities of school dropout tendency in orphanage and ordinary students. Notably, the study demonstrated that parental care or its absence (being an orphan or non-orphan) was playing a moderating role in the relationship between personality traits and dropout tendency.

Orphan students who exhibited higher levels of extroversion-introversion and psychoticism had the highest tendency of dropout as compared to non-orphan students. This study implicates that personality traits area more important factor for triggering dropout tendency in orphanage students than in ordinary school students. Therefore, the research recommends special intervention by clinical and pedagogical settings in the case of orphanage students to help resolve personality conflicts in order to prevent dropouts. These findings could have profound impact on future policy and program planning for orphans in developing countries.

*Key word.* Personality traits, dropout tendency, orphan and non-orphan students

- 
1. *Research Scholar, Department of Psychology, University of Memphis.*
  2. *Lecturer, Department of Psychology, Foundation University, Rawalpindi Campus.*
  3. *Research Scholar, Department of English, Foundation University, Rawalpindi Campus.*
  4. *Research Scholar, School of Social Sciences and Humanities, NUST*

*Correspondence concerning this article should be addressed to Ms. Rimsha Majeed,  
Department of Psychology, University of Memphis, USA.  
Email:rimshamajeed100@gmail.com*

There is some debate among scholars that orphan students tend to have a greater dropout tendency as compared to students under parental care (Lantz, House, Lepkowski, Williams, Mero & Chen, 1998; Krueger, Markon, Patrick, Benning, & Kramer, 2007; Anwar, Tahir, Batool & Ghori, 2012; Dontsov, Perelygina, & Veraksa, 2016; Maqbool & Ganai, 2016; Migali, & Zucchelli, 2017; Ahmed, Ammar Ahmed, Akhtar, & Salim, 2017; Cisheng et al., 2017; Jami & Kamal, 2017; Kalsoom, Masood, & Jami, 2017; Khan, Amanat, Aqeel, Sulehri, Amanat, Sana, & Amin, 2017). The underpinnings of the association between personality traits and dropout tendency are not completely implicit, with at least one common clarification having been presented. For example, this association may be affected by a third variable causing both personality traits and dropout tendency. Student status of being an orphan or a non-orphan was proposed as a variable likely to influence the association (Krueger, Markon, Patrick, Benning, & Kramer, 2007; Dontsov, Perelygina, & Veraksa, 2016; Migali, & Zucchelli, 2017). Many prior studies investigated the relationship between personality traits and dropout tendency in school students (Krueger, Markon, Patrick, Benning, & Kramer, 2007; Dontsov, Perelygina, & Veraksa, 2016; Migali, & Zucchelli, 2017). Migali and Zucchelli (2017) and found that extraversion, neuroticism and psychoticism traits of personality were positively related to dropout tendency and they suggested that dropout tendency probably varies in orphan and non-orphan students. This current paper investigated the influence of personality traits on the school dropout tendencies in orphan students studying in orphanages, and carried out a comparison with ordinary school students to see how the same personality traits were affecting their dropout tendencies.

There is a consensus among scholars that dropping out from school is a crucial dilemma in high-schools all over the world. It is a deleterious phenomenon in every socio-economic group (Henry & Huizinga, 2007; Maynard,

McCrea, Pigott & Kelly, 2013; Bibi, Sobia, Mustanir & Sana 2017; Peter, Abbas, Aqeel, Akhtar, & Farooq, 2017; Hussain, Rohail, & Ghazal, 2017; Rehna & Hanif, 201; Aftab & Malik, 2017). Its harmful consequences manifest in destructive learner behavior such as drug abuse, poor school performance, delinquency, and conduct disorder (U.S. Department of Education, 1996; Baker, 2000; Carney, Timms, & Stevenson, 2006; Henry & Huizinga, 2007; Gary & Newsome, 2008; Maynard, Salas-Wright, Vaughn & Peters, 2012). The tendency of dropping out from school is universally dubbed and widely recognized as a negative life event and is believed to act as a catalyst to further negativities in life. (Sweeten, 2004). A survey carried out on government colleges of Punjab, Pakistan revealed that the rate of student dropout at the higher secondary education level was almost ten percent in the years 2003-2007 (Anwar, Tahir, Batool & Ghor, 2012; Maqbool & Ganai, 2016). In comparison, amongst the age group of 25 to 34 years, this figure rose to 13 percent at the national level. Potentially, this tendency can lead to several financial issues (U.S. Census Bureau, 2002). According to the U.S. Census Bureau (2002) Population Survey, median annual earnings for individuals (at least 25 years of age) without high school education was \$15,800, while the median annual earnings for high school dropouts was \$18,445. In sharp contrast, the median annual income for high school graduates, including GED holders, was \$24,656 (U.S. Census Bureau, 2002). In addition to this sharp decline in income, dropouts were also found to be more prone to risky health behaviors such as smoking, obesity, and decreased levels of physical activity (Lantz, House, Lepkowski, Williams, Mero & Chen, 1998). These and a host of other negative consequences (related to the act of dropping out) make it imperative that due attention be given to this aspect.

High school dropping out is still an important policy matter with an incidence of over 20% in most developing countries (OECD, 2012). Initial dropout significantly enhances the risk of joblessness, poorer health status, domestic violence, and delinquency (Thornberry, Moore, & Christenson, 1985; Chapman,

Laird, & Kewal Ramani, 2010; Heckman & LaFontaine, 2010; Almlund, Duckworth, Heckman, & Kautz, 2011). Additionally, the former contributions shed light on the influence of locus of control and personality traits (Cebi, 2007; Coleman & DeLeire, 2003). As per recent studies, many scholars believe that personality traits may play a crucial role in making educational decisions. However, prior studies focus on the effects of personality traits on high school dropout tendency. Moreover, different traits of personality might differentially lead to dropout tendency (Eckstein & Wolpin, 1999). Previous studies documented that conscientiousness and agreeableness traits of personality were negatively associated with drug addiction and high school dropout (Vollrath, Knoch, & Cassano, 1999; Almlund et al., 2011; Kern & Friedman, 2011).

Previously, researchers have identified several factors associated with dropouts. To name a few, low socioeconomic status, low parental educational or occupational attainment, low family income, non-English-speaking homes, single-parent families, and lack of learning materials in the home were predictors of dropout (Rumberger 1987). In addition to these, certain other factors (but with less evidence) were peers' attitudes and behaviors, inadequacy of school facilities and resources, and economic factors (Rumberger 1987). It was also determined that personality factors were also a fundamental cause of the drop-out phenomenon. To elucidate this aspect, it may be highlighted that many of the drop-out cases were found to harbor behavior problems or delinquent behavior (Battin-Pearson, Newcomb, Abbott, Hill, Catalano & Hawkins, 2000). In fact, Jimerson, Anderson and Whipple (2002) emphasized that grade retention was the strongest predictor of school dropout. Furthermore, the dropout population was found to be predisposed to social withdrawal, high levels of anxiety and depression (Marcotte, Fortin, Royer, Potvin & Leclerc, 2001).

A probe into the researches carried out so far also revealed that behavior problems were one of the early predictors of school drop-out (Garnier, Stein & Jacobs, 1997). In fact, at the end of primary school, the intensity of such problems becomes the strongest predictor of the school dropout tendency (Jimerson, Egeland, Sroufe & Carlson, 2000; Hassan, Jami, & Aqeel, 2016; Aqeel, Anjum, Jami, Hassan, & Sadia, 2016; Aqeel, Jami, & Ahmed, 2017; Aqeel, & Akhtar, 2018). Furthermore, living in a single parent family can further exacerbate this effect.

Eysenck's theory provides an insight into the effects of 'orphan' and 'non-orphan' status on those personality traits which help to determine and predict drop-out tendency. As a primer, UNICEF classifies any child that has lost one parent as an 'orphan' and estimated in 2004 that approximately 143 million children were orphans at that time (UNICEF, 2004). In fact, a child who is below 18 years of age and who has lost one or both parents may be defined as an 'orphan' (George, 2011). A 'maternal orphan' is one who has lost his/her mother and 'paternal orphan' is referred to as a child who has lost his/her father. Social orphans are children who are living without parents because of abandonment or because their parents gave them up as a result of poverty, alcoholism or imprisonment (Dillon, 2008).

It may be kept in consideration that personality traits are relatively enduring patterns of thoughts, feelings, and behaviors that distinguish individuals from one another. (Roberts & Mroczek, 2008). Eysenck (1970) illustrates that there are two dimensions of personality. These two dimensions can be classified as "Extraversion-Introversion", and "Neuroticism-Psychoticism". While previous research supports the finding that personality traits affect a student's drop-out tendency, Astin and Alexander suggest that dropouts tend to be more aloof, self-centered, impulsive, and assertive than non-dropouts (1964). Review of literature has also

identified that personality traits such as interpersonal affect and conformity facilitated the process of adjustment, while traits such as anxiety worked in the opposite direction. Likewise, empathy also emerged as a significant contributor to the social adjustment (Nagle and Anand, 2012). Testing Eysenck's theory that delinquents should be high scorers on extroversion neuroticism and psychoticism, Rushton & Chrisjohn (1981) found that there was a definite relationship between high scores on delinquency and high scores on extroversion and psychoticism.

The impact of personality traits on drop-out tendency has been studied before. However, it has not been studied separately for orphan students. The current study aims to fill this gap and compare this prediction both amongst orphan and non-orphan students in order to determine whether this social status has a moderating effect on the personality traits which lead to drop-out tendencies or not. Apart from this, the study aims to test whether Eysenck's theory of personality traits and delinquency (Rushton & Chrisjohn, 1981) can be applied to the orphan population as well.

## **Method**

### **Objective**

1. To study the moderating role of student status (orphan and non-orphan) on the relationship between personality traits and dropout tendency.

### **Sample**

Purposive sampling technique was employed based on cross-section design. The data of current study encompassed of 200 participants (orphan,  $n = 100$ ; non-orphan students,  $n = 100$ ) were incorporated from different orphan age schools and high schools of Rawalpindi and Islamabad, Pakistan. Age ranged from 12-18 years.

## **Instrument**

**Eysenck Personality Questionnaire (EPQ).** Eysenck personality questionnaire (Eysenck, Eysenck, & Barrett, 1985; Naqvi & Kamal, 2010) was used to measure extraversion-introversion, neuroticism, psychoticism, and lie traits of personality in orphan and non-orphan students. This instrument comprises on 81-items that asked students to rate their level of agreement for each items on a *1(yes)* to *3 (sometimes)* scale. Four dimensions were measured by EPQ; extraversion-introversion, neuroticism, psychoticism and lie (Naqvi & Kamal, 2010). The Extraversion – introversion subscale consists of 24 items (item number 1, 5, 9, 13, 17, 21, 25, 28, 33, 37, 41, 44, 48, 52, 56, 58, 61, 65, 67, 70, 74, 76, 79 & 81); the Neuroticism subscale consists of 20 items (item number 2, 6, 10, 14, 18, 22, 26, 29, 34, 38, 45, 49, 53, 59, 62, 66, 68, 71, 77 & 80); the Psychoticism subscale consists of 17 items (item number 3, 7, 12, 15, 19, 23, 30, 32, 35, 39, 42, 46, 50, 54, 57, 63 & 72); and the Lie subscale consists of 20 items (item number 4, 8, 11, 16, 20, 24, 27, 31, 36, 40, 43, 47, 51, 55, 60, 64, 69, 73, 75 & 78). There are negative items in the subscales, Psychoticism (item number 30, 63 & 72); Extraversion (item number 9, 48 & 76) and Lie (item number 4, 11, 16, 40, 64, 69, 75 & 78). Negative items follow reverse scoring. For all personality 's traits, the higher scores shown more prevalence of that specific personality 's traits, while lower scores demonstrate lesser level of personality 's traits.

### **The School Refusal Assessment Scale – Revised (SARS-R).**

School refusal assessment scale-revised (Kearney, 2002) was used to assess dropout tendency in orphan and non-orphan students. This scale consists on 18-items that are used for assessing adolescents and children encountering school refusal behavior. The scale incorporates a practical/functional model of school refusal (Kearney & Silverman, 1990). Four dimensions were measured by SARS-R; functional/practical dimensions or the subscales are: (a) avoidance of school-related stimuli provoking negative affectivity, (b) escape from aversive social or evaluative situations, (c) garnering parental attention, and (d) Positive



tangible reinforcement. For all dropout tendencies, the higher scores shown more prevalence of that specific dropout tendency, whereas lower scores demonstrate lesser level of dropout tendencies.

### **Procedure**

The data of 200 participants (orphan students,  $n = 100$ ; non-orphan students,  $n = 100$ ) were included from different orphanage schools and high schools of Rawalpindi and Islamabad, Pakistan. Age ranged from 12-18 years. The researcher approached different orphanage schools and ordinary non-orphan schools and colleges of Rawalpindi and Islamabad. After obtaining consent from the principal, questionnaires were distributed to classes that fell under our required age range. In each class a researcher was present who gave instructions about filling the questionnaire and stayed till the end in order to answer queries. This study was endorsed by Foundation University, Rawalpindi Campus, Pakistan.

### **Results**

In the First steps of analysis, missing values of school refusal and personality traits scale were dealt via an imputation method on Spss-18 (Field, 2009). Moderation analysis was performed in present study to study the moderating role of student status (orphan and non-orphan) on the relationship between personality traits and dropout tendency through the statistical package of SEM-18 (Byrne, 2016; Lin & Hsieh, 2010; Baron & Kenny 1986).

**Table 1**

*Moderating role of student status (orphans and non-orphans) between personality traits and dropout tendency (N=200).*

Variables	Dropout			ASPNA			EASES			PAO			PTROS			
	B	SE	β	B	SE	β	B	SE	β	B	SE	B	B	SE	B	
<i>Non-Orphan students(N=100)</i>																
Psy	2.34	.80	.39**	.54	.2	.26*	.62	.22	.33**							
Lie				-.49	.22	-.28*								-.71	.25	-.33**
Ext_int												-.08	.26	-.04		
<i>Orphan students(N=100)</i>																
	B	SE	B	B	SE	β	B	SE	β	B	SE	B	B	SE	B	
Psy	1.57	.81	.25*	.56	.25	.30*	.54	.22	.31*					-.09	.16	-.07
Lie				.18	.17	.14										
Ext_int												.58	.22	.32**		

*Note.* Psy = Psychoticis; Ext\_int= Extrovert-introvert; Lie= Lie scale; ASPNA=Avoidance of school-related stimuli provoking negative affectivity; EASES= Escape from aversive social or evaluative situations, PAO=Garnering parental attention, PTR= Positive tangible reinforcement.

This table demonstrated fit data adequately,  $\chi^2(10) = 31.22$ ,  $p < .001$ ,  $\chi^2/df = 1.30$ , RMSEA= .07(.06, .13), CFI = .91, NFI = .90, IFI= .93, TLI = .91. The result of table illustrated that that psychoticism traits of personality was predicting to dropout tendency dropout tendency ( $\beta=.39$ ,  $p < .001$ ), avoidance of school-related stimuli provoking negative affectivity ( $\beta=.26$ ,  $p < .05$ ), and Escape from aversive social or evaluative situations ( $\beta=.33$ ,  $p < .001$ )for non-orphan students . The table also elaborated that lie traits of personality was predicting to avoidance of school-related stimuli provoking negative affectivity ( $\beta=-.28$ ,  $p < .05$ ) and Positive tangible reinforcement ( $\beta=-.33$ ,  $p < .001$ ) for non-orphan students. On the other hand, The result of table illustrated that that psychoticism traits of personality was predicting to dropout tendency ( $\beta=.25$ ,  $p < .05$ ), avoidance of school-related stimuli provoking negative affectivity ( $\beta=.30$ ,  $p < .05$ ), and Escape from aversive social or evaluative situations ( $\beta=.31$ ,  $p < .001$ ) for orphan students. The results also indicated that extrovert-introvert was predicting to garnering parental attention ( $\beta=.32$ ,  $p < .001$ ) for orphan students.

## Linking Personality Traits and School Dropout Tendency: Evidence from Pakistan Orphan and Non-Orphan Students

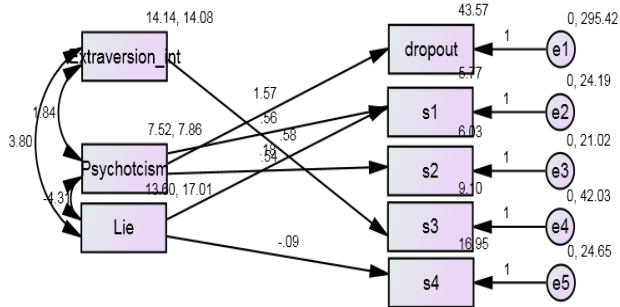

Figure 1 for orphan students  
Moderating Role of students types(orphan students and non orphan students) between personality traits and dropouts tendency.

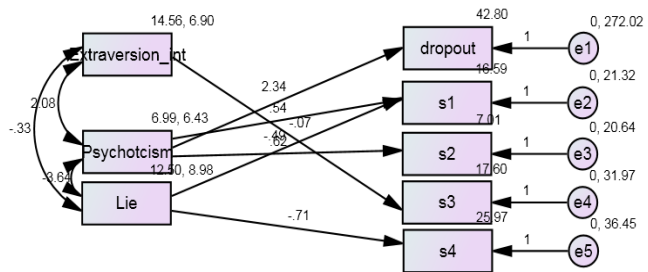

Figure 2 for Non-orphan students  
Moderating Role of students types(orphan students and non orphan students) between personality traits and dropouts tendency.

## Discussion

This current paper was designed to investigate the overlook influence of personality traits on school dropout tendency of orphan and non-orphan students. Moreover, to investigate the moderating role of student status (orphan or non-orphan students) on the relationship between personality traits and dropout tendency.

Regarding to objective no.1 which stated that to investigate the moderating role of student status (orphan or non-orphan students) on the relationship between personality traits and dropout tendency was supporting in current study. These study findings demonstrated that extrovert-introvert traits of personality were linked to more likelihood of school dropout tendency in orphan students. This study estimates shown that blends of low prevalence of neuroticism exposed more probabilities of an early exit. On the other hand, this study also illustrated psychoticism and lie traits of personality were associated with higher probabilities of school dropout tendency in orphan and non-orphan students. This current finding of study demonstrated that student status (orphan and non-orphan students) was playing role of moderator on the relationship between personality traits and drop out tendency. Orphan students who have been shown higher levels of extroversion, introversion and psychoticism have the highest tendency of dropout as compared to non-orphan students. This current study results consistent with previous numerous study findings (Battin-Pearson et al., 2000; Fortin & Picard, 1999; Maqbool & Ganai, 2016; Rushton & Chrisjohn, 1981). Many prior studies investigated the relationship between personality traits and dropout tendency in school students (Dontsov et al., 2016; Krueger et al., 2007; Migali & Zucchelli, 2017). Migali, and Zucchelli (2017) found that extrovert, neuroticism and psychoticism traits of personality were positively related to dropout tendency and they

suggested that dropout tendency is probably vary in orphan and non orphan students.

Dropouts have behavior problems or delinquent behavior of learner (Battin-Pearson et al., 2000; Fortin & Picard, 1999). Previous research has shown a relationship between ‘extroversion’ and ‘delinquency’ (Rushton & Chrisjohn, 1981). The current research shows a similar pattern for orphan students but not for non-orphan students. A reason supporting this could be that since orphan students have lost their fathers, they are more likely to garner for their mother’s attention as they may be experiencing separation anxiety (American Psychiatric Association, 2013; Aqeel, Jami, & Hassan, 2015; Munawar, Aqeel, & Husain, 2015; Hassan, Aqeel, & Jami, 2015; Sadia, Aqeel, & Jami, 2015). Research has also shown support for a relationship between high delinquency scores and high scores on Psychoticism (Rushton & Chrisjohn, 1981). These finding are consistent with the current research for both orphan and non-orphan students. Research has shown that social anxiety is among the most prevalent and debilitatingly affective disturbance and is manifested in people with psychosis (Mazeh et al., 2009; Michail & Birchwood, 2009; Pallanti, Quercioli, & Hollander, 2004). This perhaps explains why a prediction between psychoticism trait and drop-out tendency was seen. Rushton & Chrisjohn(1981), while testing Eysenck’s theory, discovered that psychoticism and extroversion were associated with delinquency. These findings are consistent with the findings shown for orphan students in the present study; thus proving that Eysenck’s theory of delinquency can be effectively applied to orphan students.

The present research can be helpful in pedagogical and clinical settings to assess the risk of drop-out tendencies so timely prevention can be done. Students showing personality traits that predict dropout tendency can be counseled to prevent drop-out.

Since the current research discriminates between orphan and non-orphan students, wrong generalizations can be avoided. Moreover, both the orphan and non-orphan population can benefit from this study. Furthermore, this study shows how conversion from non-orphan to orphan can expose a child to another factor that can lead to dropout tendency; and that is, “garnering parental attention”. This can also be helpful in the counseling of students who have lost a parent. Reflecting on the present study, further research may be carried out to assess what prevention or intervention strategies may be useful for both populations. The sample of the present study was limited and didn’t take into account the effect of gender, however, future researches may be carried out with a larger sample while taking into account the effect of gender as well.

### **Conclusion**

This current paper concluded that extraversion-introversion, neuroticism, and psychoticism traits of personality may lead to a dropout tendency in orphan students. Findings also yielded that the demographic variable of being an orphan or non-orphan student strongly correlated with a dropout tendency. For instance, orphan students who had extrovert traits of personality were more predisposed to developing a dropout tendency as compared to non-orphan students. Personality traits are therefore a significant factor in creating dropout tendencies in orphan students.

## References

- Aftab, S. R., & Malik, J. A (2017). Mediating Role of Career Thoughts for the Effect of Career Exploration on Career Decision Making.
- Ahmed, B., Ammar Ahmed, M. A., Akhtar, T., & Salim, S. (2017). Impact of tinnitus perception on psychological distress in male and female tinnitus patients. *Foundation University Journal of Psychology 1(1)2017*, 56-67.
- Almlund, M., Duckworth, A. L., Heckman, J., & Kautz, T. (2011). Personality psychology and economics *Handbook of the Economics of Education* (Vol. 4, pp. 1-181): Elsevier.
- American Psychiatric Association. (2013). Diagnostic and statistical manual of mental disorders (5th ed). *Washington, DC: American Psychiatric Association*.
- Anwar, M., Tahir, T., Saeed, S., & Ghori, U. K. (2012). High dropout contributes to low literacy rate in pakistan: comparison of dropout at hssc and college level in pakistan. *Academic Research International*, 3(2), 398.
- Astin, A. W. (1964). Personal and environmental factors associated with college dropouts among high aptitude students. *Journal of Educational Psychology*, 55(4), 219.
- Aqeel, M., Anjum, U., Jami, H., Hassan, A., & Sadia, A. (2016). Perceived Parental School Involvement and Problems Faced by Students: Comparison of Truant and Punctual Students. *Pakistan Journal of Psychological Research*, 31(1), 241.
- Aqeel, M., Jami, H., & Ahmed, A. (2017). Translation, adaptation, and cross-language validation of student: thinking about my homework scale (STP). *International Journal of Human Rights in Healthcare*, 10(5), 296-309.
- Aqeel, M., & Akhtar, T. (2018). Self or Others: Exploring the Role of Truancy as the link between Personality Traits and Peer Influences found in Truant Students. *GSTF Journal of Psychology (JPsych)*, 3(2).
- Aqeel, M., Jami, H., & Hassan, A, (2015). School truancy: parental contribution in truancy. Germany: Lambert Publications.

- Baker, M. L. (2000). Evaluation of the truancy reduction demonstration program: Interim report. *Denver: Colorado Foundation for Families and Children.*
- Battin-Pearson, S., Newcomb, M. D., Abbott, R. D., Hill, K. G., Catalano, R. F., & Hawkins, J. D. (2000). Predictors of early high school dropout: A test of five theories. *Journal of Educational Psychology, 92*(3), 568.
- Berliner, D. C., & Biddle, B. J. (1996). The manufactured crisis: Myths, fraud, and the attack on America's public schools. *Nassp Bulletin, 80*(576), 119-121.
- Bibi, S., Masood, S., Ahmad, M., & Bukhari, S. Effect of Self-Compassion on the Marital Adjustment of Pakistani Adults.
- Cebi, M. (2007). Locus of control and human capital investment revisited. *Journal of Human Resources, 42*(4), 919-932.
- Chapman, C., Laird, J., & Ifill, N. (2011). KewalRamani (2010). *Trends in high school dropout and completion rates in the united states: 1972–2009, 2012-2006.*
- Cisheng, W., Shah, M. S., Jamala, B., Aqeel, M., Ahmed, A., & Gul, M. (2017). The moderating role of spiritual intelligence on the relationship between emotional intelligence and identity development in adolescents. *Foundation University Journal of Psychology, 1*(1), 78-103.
- Coleman, M., & DeLeire, T. (2003). An economic model of locus of control and the human capital investment decision. *Journal of Human Resources, 38*(3), 701-721.
- Comings, D. E., Gade-Andavolu, R., Gonzalez, N., Wu, S., Muhleman, D., Blake, H., . . . Darakjy, S. (2000). Multivariate analysis of associations of 42 genes in ADHD, ODD and conduct disorder. *Clinical genetics, 58*(1), 31-40.
- Dillon, S. (2009). The missing link: a social orphan protocol to the United Nations Convention on the Rights of the Child. *Admin. & Reg. L. News, 35*, 7.
- Dontsov, A. I., Pereyгина, E. B., & Veraksa, A. N. (2016). Manifestation of Trust Aspects with Orphans and Non-Orphans. *Procedia-Social and Behavioral Sciences, 233*, 18-21.



- Eckstein, Z., & Wolpin, K. I. (1999). Why youths drop out of high school: The impact of preferences, opportunities, and abilities. *Econometrica*, 67(6), 1295-1339.
- Eysenck, S. B., Eysenck, H. J., & Barrett, P. (1985). A revised version of the psychoticism scale. *Personality and individual differences*, 6(1), 21-29.
- Fortin, L., & Picard, Y. (1999). Les élèves à risque de décrochage scolaire: facteurs discriminants entre décrocheurs et persévérants. *Revue des sciences de l'éducation*, 25(2), 359-374.
- Garnier, H. E., Stein, J. A., & Jacobs, J. K. (1997). The process of dropping out of high school: A 19-year perspective. *American educational research journal*, 34(2), 395-419.
- George, A. (2011). State of orphans in the earthly paradise. *Economic and Political Weekly*, 19-22.
- Heckman, J. J., & LaFontaine, P. A. (2010). The American high school graduation rate: Trends and levels. *The review of economics and statistics*, 92(2), 244-262.
- Henry, K. L., & Huizinga, D. H. (2007). School-related risk and protective factors associated with truancy among urban youth placed at risk. *The journal of primary prevention*, 28(6), 505-519.
- Hobbs, F., & Stoops, N. (2002). US Census Bureau, Census 2000 Special Reports, Series CENSR-4. *Demographic trends in the 20th century*, 24, 27-28.
- Hussain, K., Rohail, I., & Ghazal, S. Identification of Emotional and Social Difficulties among Pakistani Adolescents.
- Hassan, A., Jami, H., & Aqeel, M. (2016). Academic Self-Concept, Self-Esteem, and Academic Achievement among Truant and Punctual Students. *Pakistan Journal of Psychological Research*, 31(1), 223.
- Hassan, A, Aqeel, M., & Jami, H, (2015). School truancy and academics of the children. Germany: Lambert Publications.

- Jami, H., & Kamal, A. (2017). Myths about hijras (male-to-female transgender of hijra community)? role of gender and commonly held belief about them. *Foundation University Journal of Psychology, 1*(1), 63-76.
- Jimerson, S., Egeland, B., Sroufe, L. A., & Carlson, B. (2000). A prospective longitudinal study of high school dropouts examining multiple predictors across development. *Journal of school psychology, 38*(6), 525-549.
- Kearney, C. A. (2002). Identifying the function of school refusal behavior: A revision of the School Refusal Assessment Scale. *Journal of psychopathology and Behavioral Assessment, 24*(4), 235-245.
- Kearney, C. A., & Silverman, W. K. (1990). A preliminary analysis of a functional model of assessment and treatment for school refusal behavior. *Behavior Modification, 14*(3), 340-366.
- Kern, M. L., & Friedman, H. S. (2011). Personality and pathways of influence on physical health. *Social and Personality Psychology Compass, 5*(1), 76-87.
- Khan, A., Amanat, A., Aqeel, M., Sulehri, N. A., Sana, E., Amin, H., & Amanat, A. (2017). The mediating role of job stress between social support and development of stress, anxiety and depression in educators and health professionals. *Foundation University Journal of Psychology 1* (1), Jan 2017, 38.
- Krueger, R. F., Markon, K. E., Patrick, C. J., Benning, S. D., & Kramer, M. D. (2007). Linking antisocial behavior, substance use, and personality: An integrative quantitative model of the adult externalizing spectrum. *Journal of abnormal psychology, 116*(4), 645.
- Lantz, P. M., House, J. S., Lepkowski, J. M., Williams, D. R., Mero, R. P., & Chen, J. (1998). Socioeconomic factors, health behaviors, and mortality: results from a nationally representative prospective study of US adults. *Jama, 279*(21), 1703-1708.
- Maqbool, A., & Ganai, M. Y. (2016). *A Study of Self-Concept, Mental Health and Academic Achievement of Orphan and Non-Orphan Adolescents*: Anchor Academic Publishing.

- Marchal, V., Dellink, R., Van Vuuren, D., Clapp, C., Chateau, J., Magné, B., & van Vliet, J. (2011). OECD environmental outlook to 2050. *Organization for Economic Co-operation and Development*.
- Marcotte, D., Fortin, L., Royer, É., Potvin, P., & Leclerc, D. (2001). L'influence du style parental, de la dépression et des troubles du comportement sur le risque d'abandon scolaire. *Revue des sciences de l'éducation*, 27(3), 687-712.
- Munawar, M., Aqeel, M., & Husain, W. (2015). School truancy: psychosocial factors in truancy. Germany: Lambert Publications.
- Maynard, B. R., McCrea, K. T., Pigott, T. D., & Kelly, M. S. (2013). Indicated truancy interventions for chronic truant students: A Campbell systematic review. *Research on Social Work Practice*, 23(1), 5-21.
- Mazeh, D., Bodner, E., Weizman, R., Delayahu, Y., Cholostoy, A., Martin, T., & Barak, Y. (2009). Co-morbid social phobia in schizophrenia. *International Journal of Social Psychiatry*, 55(3), 198-202.
- Michail, M., & Birchwood, M. (2009). Social anxiety disorder in first-episode psychosis: incidence, phenomenology and relationship with paranoia. *The British Journal of Psychiatry*, 195(3), 234-241.
- Migali, G., & Zucchelli, E. (2017). Personality traits, forgone health care and high school dropout: Evidence from US adolescents. *Journal of Economic Psychology*, 62, 98-119.
- Nagle, Y. K., & Anand, K. (2012). Empathy and personality traits as predictors of adjustment in Indian youth. *Industrial psychiatry journal*, 21(2), 125.
- Naqvi, I., & Kamal, A. (2010). Translation and adaptation of Eysenck Personality Questionnaire (Junior) and its Validation with Laborer Adolescents. *Pakistan Journal of Psychology*, 41(2).
- Pallanti, S., Quercioli, L., & Hollander, E. (2004). Social anxiety in outpatients with schizophrenia: a relevant cause of disability. *American Journal of Psychiatry*, 161(1), 53-58.

- Peter, S., Abbas, J., Aqeel, M., Akhtar, T., & Farooq, K. The Moderating Role of Pregnancy Status among Coping Strategies, Depression, Anxiety and Stress across Pakistani Married Women.
- Rehna, T., & Hanif, R. Verbal Cognitive Abilities and Emotional and Behavioral Problems of Secondary School Children. *Foundation University Journal of Psychology*, 1(2), 20-35.
- Roberts, B. W., & Mroczek, D. (2008). Personality trait change in adulthood. *Current directions in psychological science*, 17(1), 31-35.
- Rumberger, R. W. (1987). High school dropouts: A review of issues and evidence. *Review of educational research*, 57(2), 101-121.
- Rushton, J. P., & Chrisjohn, R. D. (1981). Extraversion, neuroticism, psychoticism and self-reported delinquency: evidence from eight separate samples. *Personality and individual differences*, 2(1), 11-20.
- Sadia, A., Aqeel, M., & Jami, H, (2015). School truancy: personality and peer influence in truancy. Germany: Lambert Publications.
- Sweeten, G. A. (2004). *School dropout and subsequent offending: Distinguishing selection from causation*.
- Thornberry, T. P., Moore, M., & Christenson, R. (1985). The effect of dropping out of high school on subsequent criminal behavior. *Criminology*, 23(1), 3-18.
- Unicef, (2004). *Building child friendly cities: A framework for action*: UNICEF Innocenti Research Centre.
- Vollrath, M., Knoch, D., & Cassano, L. (1999). Personality, risky health behaviour, and perceived susceptibility to health risks. *European journal of personality*, 13(1), 39-50.